

Development and Demonstration of Ground Coupled Heat Pumps of High Technology

Luís Coelho, Rita Cerdeira, João Garcia, Burkhard Sanner, Marcel Abry, Constantine Karytsas

Escola Superior de Tecnologia de Setubal, Campus do IPS, Estefanilha

rcerdeira@est.ips.pt

Keywords: Ground Source Heat Pumps, High technology, Demonstration site.

ABSTRACT

Ground Source Heat Pumps are starting to be used in Portugal. College of Engineering and Technology (ESTSetubal) from Polytechnic Institute of Setubal has participated in an European Project - GROUNDHIT project- as demonstration site for Ground Source Heat Pumps (GSHP) - 2 x 15 KWheating; 2 x 12 KWcooling - with a high energetic efficiency. The main goal was to monitor the prototype of improved energy efficiency (COP = higher than 5,5) in real conditions and test two different Boreholes Heat Exchangers (BHE) types, double-U pipes and coaxial pipes, to acclimatize 7 office rooms and 2 class rooms, in Portuguese climate.

Boreholes had good performance during the preliminary monitoring tests, as well as the integrated systems, which show that the GSHP running under real conditions can reach values of COP between 5,5 - 6,0 in heating mode. This demo site can test GSHP's under real conditions for a southern European region and has an important role for GSHP performance evaluation in Portugal.

1. INTRODUCTION

The use of ground source heat pumps (GSHP) for heating and cooling is rather spread along many countries due to being virtually possible everywhere and the great benefits regarding energy savings and environmental aspects.

This system permits the acclimatization of buildings by using the heat within the ground, the heat in the winter and the cold in the summer. The system takes advantage of moderate constant temperatures of the ground being more efficient than the conventional systems, reducing also operational costs.

The functioning principle is the same of a normal air conditioner, capturing heat from a source and transfer it to a warmer area, against the natural direction of the flow, or increase the heat from a warmer area to a cooler one, becoming this a reversible system.

One of the great advantages of this system is the constant temperature of the ground, without seasonal variation, being the temperature warmer than the air during winter and cooler in summer.

The technology is proven to be very efficient, the main problem are the costs, since this kind of systems is considerable more expensive than conventional ones, since is not so commercial, nevertheless the pay-back period is between 3 to 10 years, depending on the installation.

This emerging potential was considered in a project, GROUNDHIT – Ground Coupled Heat Pumps of High Technology, which aimed at improving cost-effectiveness, competitiveness and market penetration of ground coupled heat pumps and to demonstrate the performance of the system in real conditions in three demo-sites, e.g. Sanner, B. et al (2007):

- Ground source heat pump with coefficient of performance (COP) > 5.5, coupled with prefabricated borehole heat exchangers in Portugal;
- Ground source heat pump delivering 80°C hot water, coupled with prefabricated borehole heat exchangers in Austria;
- 40°C water source heat pump of COP > 7, coupled with a hot water geothermal well in Greece.

In this paper will be described the experience in Portugal.

2. SITE DESCRIPTION

The system was installed in College of Engineering and Technology (ESTSetubal) from Polytechnic Institute of Setubal (central Portugal near the sea) to acclimatize 7 office rooms and 2 classrooms.

ESTSetubal has a capacity of 2400 students and as objectives applied research and experimental development, provision of services and co-operation in national and international projects and cultural initiatives.

Setubal is a city in the middle south Portugal, located in the district of Setúbal, 50km South of Lisbon at the margins of river Sado, with a resident population of 122.554 inhabitants.

2.1 Climatic Conditions

The climatic conditions are a major concern when dealing with geothermal applications, being one of the key factors in determining the thermal energy demand.

In general, south Europe has both, cooling and heating demands. In the coast the climate is more pleasant due to the proximity to the sea, contrary to the mainland regions that have summers and winters more demanding.

Setubal is a small town near Lisbon with temperate climate due to the sea proximity. The temperature is pleasant being the average temperature of 13.5°C ($\min_{med} = 7^\circ\text{C}$) in the cold period (from November to Mars) and 20°C ($\max_{med} = 30^\circ\text{C}$) in the hot period (from April to September). The main needs in ESTSetubal are in winter months (November to February) for heating and in summer months (June to September) for cooling (not so used since there is a vacation period in August).

Regarding to solar radiation, the annual average values diverge along the year, with July being the month with greater solar radiation and December the month with less radiation. The follow figures are illustrative of the average temperature and solar radiation in Portugal.

2.2 Geological Conditions

Regarding the geology of Portugal, there is a great diversity due to the different physic - chemical composition of Portuguese mineral water. Portuguese territory has three different main structures, hesperic massif, meso-cenozoic occidental and meridional front and Tejo and Sado tertiary aquifer. Hesperic massif is formed by ancient soils with metamorphic, sedimentary and magmatic rocks from Pre-cambriaco.

In the demonstration site the soil is composed by sand and clay and has an aquifer near the surface. Figure 3 shows the demo site soil composition in depth.

In Setúbal city the soil temperature rounds between 15 and 19°C, a normal temperature for low enthalpy applications, such as GSHP.

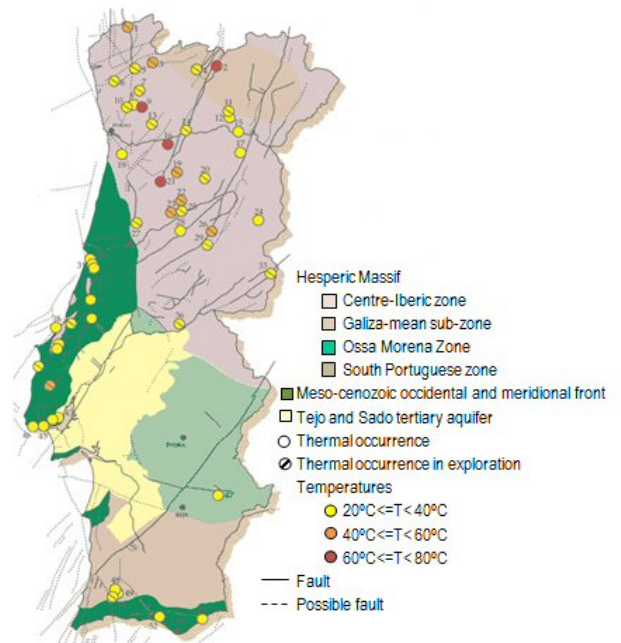

Figure 2 – Geological map with thermal occurrences (Source: INETI, Portugal)

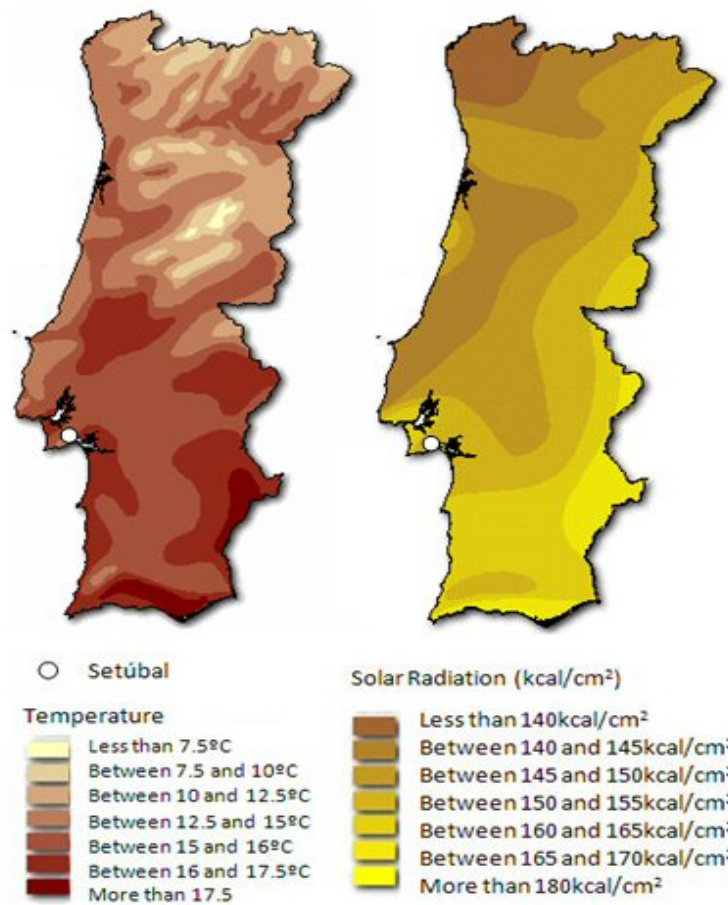

Figure 1 – Average temperature and solar radiation in Portugal - continent (Source: Environmental institute, Portugal)

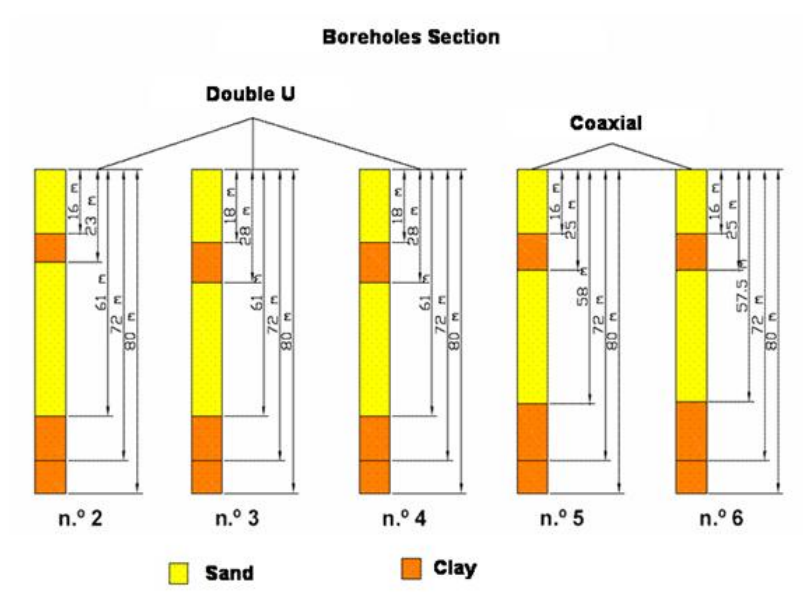

Figure 3 – Demo site soil composition in depth (Source: GeoMinho)

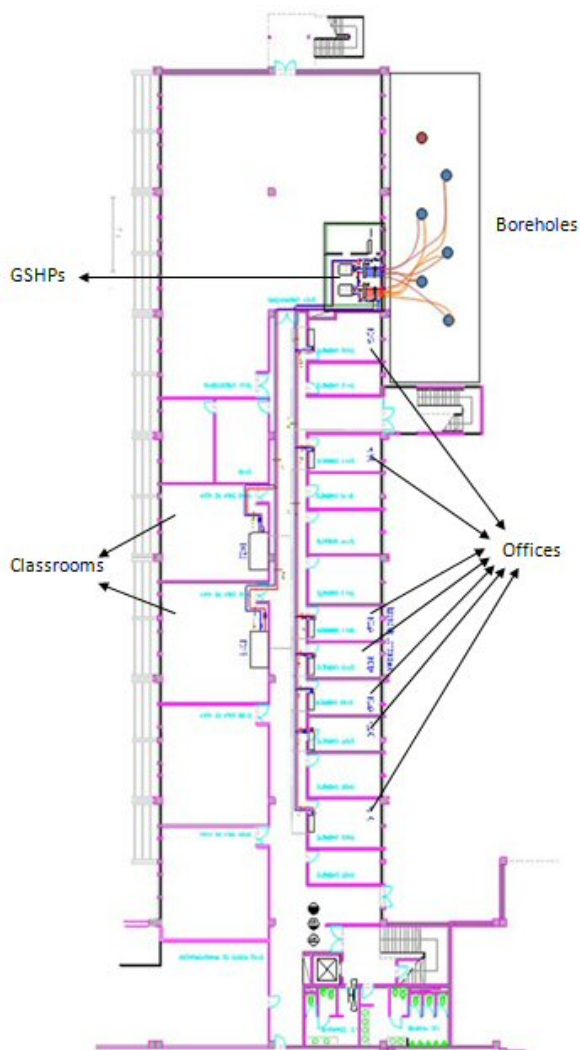

Figure 4 – Installation layout

2.3 Installation

The system was installed in the thermodynamics laboratory and is prepared to acclimatize 7 office rooms, with areas between 13 and 17m² and 2 classrooms with 63 and 65m² and a capacity of 50 places. The installation has two GSHPs, five boreholes and nine fan-coils. There is a primary water circuit between the boreholes and the GSHPs and a secondary circuit, with two distribution circuits, from the GSHPs to the room to acclimatize (figure 4).

2.3.1 Primary Circuit

The ground source heat exchangers and respective boreholes design was made by Prof. Sanner (partner of the GROUNDHIT project), considering the geological and climatologic characterization of the site.

A theoretical design of the heat pump cycle using the COOLPACK software code was performed, to study different cycle configurations and refrigerants. R410A was the selected fluid, since it's good behaviour and due to technological and market status of the manufacturers of the cycle main components, like the compressors.

Considering geological and climatologic information, characterization and needs of the spaces to acclimatize, two GSHP with 15kW each were chosen. In order to satisfy these needs, 5 boreholes were done, with 80m deep each and a diameter of 12cm. Two different types of heat exchanger were used, three double U (tested also as simple U) and two coaxial, with the objective to test the performance of these different heat exchanger configurations.

The double U heat exchanger type has an internal diameter of 32mm, while the coaxial type has an internal diameter of 60 mm of the external tube and 40mm of internal tube (figure 5).

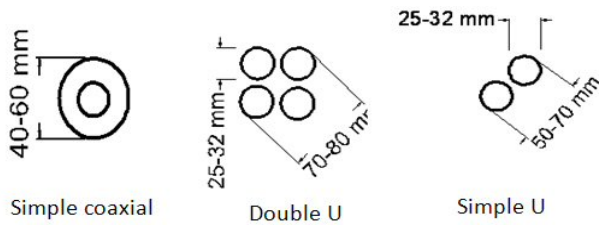

Figure 5 – Different type of ground heat exchangers (Source: Geominho, Portugal)

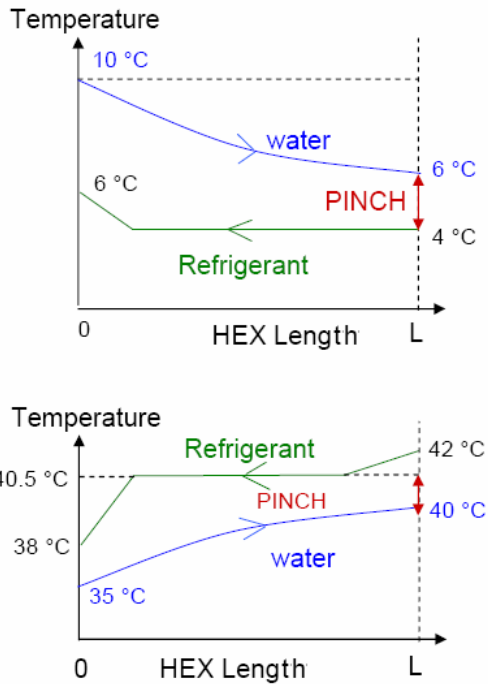

Figure 6: Temperature development in the GSHP, over the length of the heat exchanger for evaporator (above) and condenser (below)



Figure 7: Terminal units, fan-coils, in one classroom and in one office

The distance between each borehole is about 4.6m to maintain the soil temperature around each borehole, without interferences of other boreholes heat exchangers. The minimum distance between boreholes and the building wall

is 1m. All this distances, as well as the boreholes zigzag configuration (figure 4), were considered the minimum, taking into consideration the soil characteristics, to minimize the used space.

The boreholes are located near the place where the GSHP are installed (thermodynamics laboratory) and all parts near the surface are isolated to avoid heat losses. Inside the laboratory are two manifolds connected to the boreholes heat exchangers, one to collect the water from the up flow circuit and the other one to collect the water that goes down flow. These manifolds are also the connection between the primary circuit and the heat pumps.

2.3.2 Ground Source Heat Pumps (GSHP)

The advanced GSHPs were developed by CIAT in Culoz, France, one of the GROUNDHIT project partner.

To achieve a high COP in the GSHP it is necessary a good compressor efficiency and a small temperature loss both in evaporator and condenser. In this project the objective was to achieve a GSHP with less than 2K in the evaporator and less than 1K in the condenser, through a special brazed plate heat exchanger and a specific distribution device for the evaporator and also an efficient scroll type compressor without capacity control, which enables the compressor to run more under optimum efficiency conditions (the ground-coupling and hydronic heating allow for the simple on-off-control). Table 1 and Figure 6 show the lab tests, e.g. Sanner, B. et al (2007).

Table 1 – COP of GROUNDHIT GSHP prototype, vs. typical results for the best GSHP tested at Töss test centre, Switzerland

	¹ COP at 35/40°C	² COP at 30/35°C
GROUNDHIT pre-prototype	5.12	6.06
Typical value for GSHP on the market	4.5	5.4
Gain in %	14%	12%

¹GROUNDHIT nominal conditions and ²EUROVENT conditions

The high efficiency GSHP was also equipped with reversing 4 ways valve to be possible the cooling operation in summer time, DHW system production with storage tank (300 L) and CIAT micro-connect electronic regulation.

2.3.3 Secondary Circuit

The secondary circuit connects the GSHP to the terminal equipment in the rooms. Two independent systems distribute cooling/heating, one from the one GSHP to the fan coils in the 7 offices and the other one from the other GSHP to the fan coils in the 2 classrooms. Taking into account that the offices are in the west part of the building and the classrooms on the east part, it is possible to deliver heat to one part and cold to the other part. This is particularly useful in middle seasons such as spring or autumn, especially in the morning. A bypass was also introduced in case one GSHP is not functioning the system will continuing working with the other one.

Figure 7 shows the fan-coils in a classroom and in one office and figure 8 is illustrative of the 2 circuits.

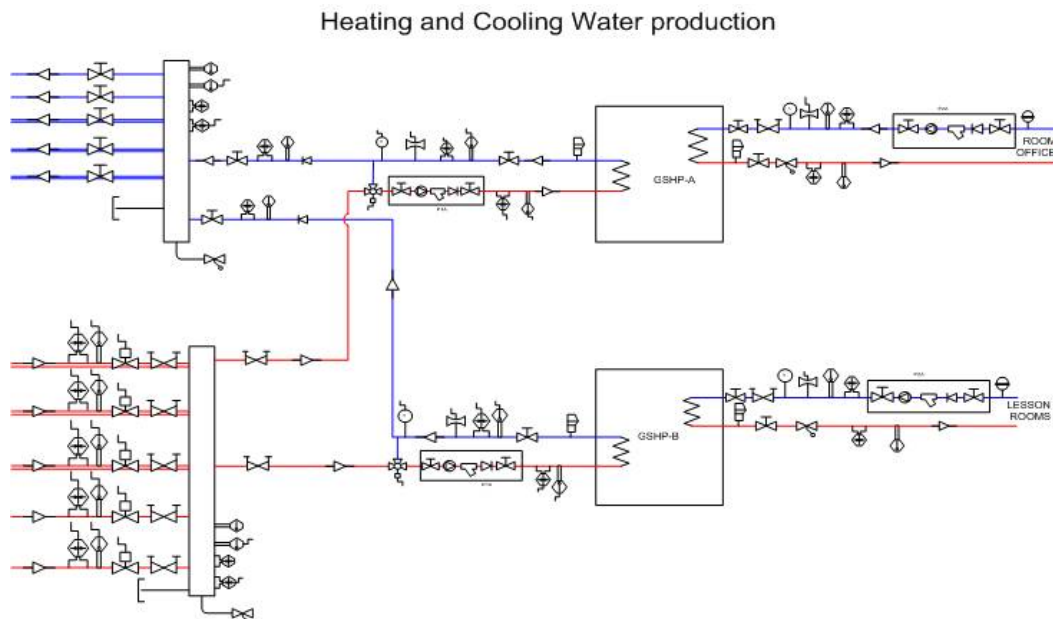

Figure 8: GSHP system scheme and monitoring points

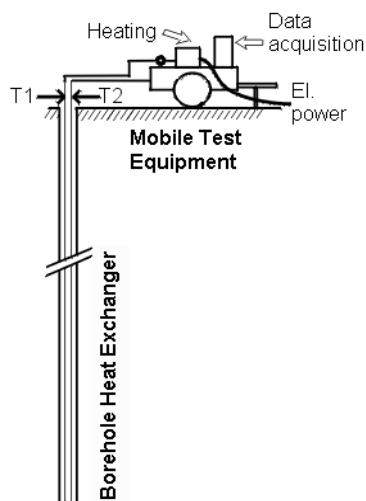

Figure 9: Typical thermal response test setup

2.3.4 Monitoring System

The two types of apparatus used in the monitoring system allow data acquisition automatically to a computer, through an acquisition module or through analogical instrumentation.

The data collected are temperature, pressure, electric consumption and flow rate.

The monitoring points are:

- Boreholes inlet and outlet temperature (°C) and pressure (bar);
- Secondary circuit inlet and outlet temperature (°C), pressure (bar) and flow rate (m³/h);
- GSHP electric consumption (kW).

3. SITE PERFORMANCE TESTS

The main objective is to quantify the efficiency of the system, considering the performance of the boreholes heat exchangers, the performance of the GSHP and the performance of the integrated system including the secondary circuit.

3.1 BHE Thermal Response Tests

These tests allowed achieving the efficiency of each BHE type, but the main purpose is to determine the effective ground thermal conductivity. Usually this test is carried out on a pilot borehole that, afterwards, will be part of the boreholes. In this kind of test, a defined, constant heat load is introduced in the borehole and the evolution of the fluid temperature, inside the hole, against time elapsed is registered. This procedure allows to sizing the boreholes according to real underground conditions. In figure 9 it is possible to see a typical test setup, e.g. Mands, E. and Sanner, B. (2001).

According to this author, the easiest way to evaluate thermal response test data makes use of the line source theory, considering the formula, e.g. Eklöf, C. and Gehlin, S. (1996):

$$k = \frac{\dot{Q}}{4\pi H \lambda_{eff}} \quad (1)$$

Where K is the inclination of the curve of temperature versus logarithmic time, Q is the heat injection/extraction (W), H is the length of BHE (m) and λ_{eff} is the effective thermal conductivity (W/m.K), respectively.

Thermal conductivity will be:

$$\lambda_{eff} = \frac{\dot{Q}}{4\pi H k} \quad (2)$$



Figure 10: Experimental device to perform the thermal response test

More complicated methods can be used, however and since the current methods results are still uncertain, this was the method used to test this installation, due to its simplicity.

According to biography (e.g. Florides, G., and Kalogirou, S. (2008), e.g. Gehlin, S. (2002), e.g. Mands, E. and Sanner, B. (2001) the duration of a thermal response test must be around 48 or 50 hours. In this installation, the first tests were made in 30 hours each, since the temperature results kept stable since the 15th hour. In the second tests the advised duration was considered.

In ESTSetubal installation the borehole and BHE were tested through an experimental device, built to study the behaviour of the two different BHE. The test was made in the heating mode.

Initially the device was constituted by a boiler with water coupled to an auxiliary gas heating equipment (Figure 10). The water circulates between the BHE and the boiler in a closed circuit with the assistance of a circulation pump. The auxiliary equipment allowed to send water with a known and constant heat load and flow through the circuit, to assess the temperature in the inflow and on the outflow.

One test was made for each kind of BHE, one for the coaxial BHE, one for the double U BHE and a third one for the simple U BHE, to achieve the performance of each kind of BHE.

The test results were monitored and recorded by an acquisition data board, which was connected to a computer with the program LabView.

The first thermal response test was carried over 7 days, from 10 September to 13 September 2007 and from 17 September to 19 September 2007.

The heating source delivers an estimated heat rate of 7.3kW for the main test range. The flow rate was fixed at a constant value of 510L/h and it was periodically checked and controlled. The measured parameters were the ambient temperature, the BHE inlet temperature and the BHE outlet temperature. Due the difficulty to keep fixed the heat rate (7.3kW) the installation was modified and the tests were repeated. A new electric resistance with a heating capacity of 8kW was installed. With the new resistance it was possible to keep fixed the heat rate. A new value of water flow rate was imposed, 612L/h. With these values is expected an inlet temperature of about 45.

Results are discussed in the analysis of the results section.

3.2 Integrated System Tests

The main objective of these tests is to achieve the efficiency of the whole system, primary circuit, heat pump and secondary circuit.

The test was done in the heating mode, and the system was working non-stop, acclimatizing all the office rooms with one of the heat pumps. Some parameters were measured in several points of the installation and the results were registered by the data acquisition module. These values were validating every hour by visual readings.

Measurements of BHE inlet and outlet temperature and secondary circuit inlet and outlet temperature were registered, as well pressure in the same points (figure 8). The flow rate was also checked and the heat pumps power consumption.

Before each start up and each 10min afterwards, all measurements were registered. This data was stored in the DAQ system and written in files with hourly average values, to simplify the calculation.

Calculated parameters are:

Heat Exchange in each circuits and boreholes:

$$\dot{Q} = C_{p_w} \cdot \dot{m}_w \cdot \Delta T \quad (3)$$

Where C_{p_w} is the calorific value of the water, \dot{m}_w is the mass water flow rate in the circuit and ΔT is the difference of the outlet and inlet temperatures.

Pressure Drop:

$$\Delta P = P_{out} - P_{in} \quad (4)$$

Electric Power (hourly average value):

$$Elect.Power = \frac{Elect.Cons.(h) - Elect.Cons.(h-1)}{h} \quad (5)$$

Coefficient of performance (COP):

$$COP = \frac{\dot{Q}}{ElectricPower} \quad (6)$$

Where \dot{Q} is the heat exchange rate in the secondary circuit.

4. ANALYSES OF THE RESULTS

4.1 Boreholes Thermal Response Tests Results

As mentioned in section 3.1, the thermal response test allows to achieve the efficiency of each BHE type and to determine the effective ground thermal conductivity.

In the first test, a defined constant heat rate of 7.3kW and flow rate of 510L/h were established and the evolution of the fluid temperature, inside the borehole, against time elapsed was registered, allowing to evaluate the boreholes in the real underground conditions.

The duration of the first thermal response test was 30 hours each (coaxial BHE, doubleU BHE and simpleU BHE), instead the recommended 48 or 50 hours.

The experimental device used for the first test was composed of a boiler with water, coupled to an auxiliary gas heating equipment (Figure 9) and a circulation pump which allow the circulation of the water, in a closed loop, between the BHE and the boiler. The test was made in the heating mode. In real conditions the heat pump driveable water to the boreholes at the temperature of 45°C. Similar test conditions were used considering the inlet trending temperature to 45°C.

The evaluation of the thermal response test data was made by using the line source theory, considering the formula (1).

Figures 11 and 12 show the evolution of inlet and outlet temperatures for double U BHE type, as well as the K value (inclination of the curve of temperature versus logarithmic time), for the first test results, e.g. Coelho, L. et al (2007).

Analyzing the graphical results of temperature evolution in time, inlet (Tin) and outlet (Tout) temperatures show the same evolution. In the first hours there is an accentuated growing until it becomes smoother and almost constant. This behaviour is due to the lower water temperature inside the BHE in the beginning of the test. As it starts to heat, with the heating equipment, the temperature rises to reach the constant temperature of about 45°C, after the initial transient heating period.

The ground thermal conductivity calculated using equation 2, was 2.28W/m°C, 2.32W/m°C and 1.88W/m°C for coaxial, double U and simple U, respectively.

The results of the first test aren't very consistent since due to the experimental heating equipment, it was not easy to maintain the heat rate constant over all the time. Some adjustments in the heat rate were done for the first phase of the tests to estimate the thermal conductivity.

However, from the first tests, in spite the non conclusive results, it is possible to say that the double U BHE shows a slightly better result, since the temperature variation is higher, and the dissipated heat is greater.

Due to the non consistent results, another attempt was made and the test was repeated, with modified equipment that by

using an electric resistance could maintain the heating load constant. Also the test was performed for a longer period.

Some preliminary results are shown in the next figures:

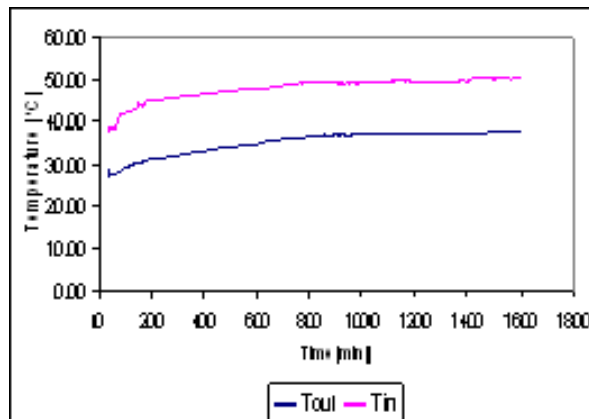

Figure 11: Evaluation Period of Double U BHE

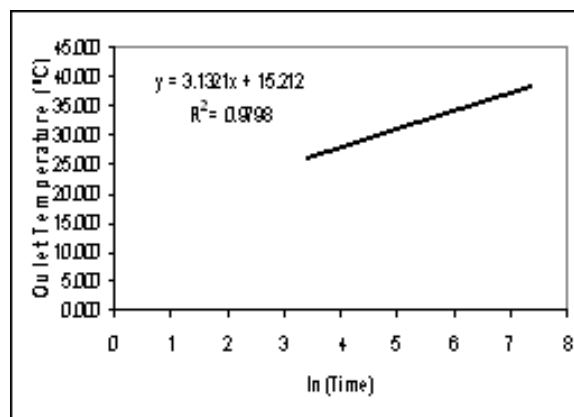

Figure 12: K determination for Double U BHE

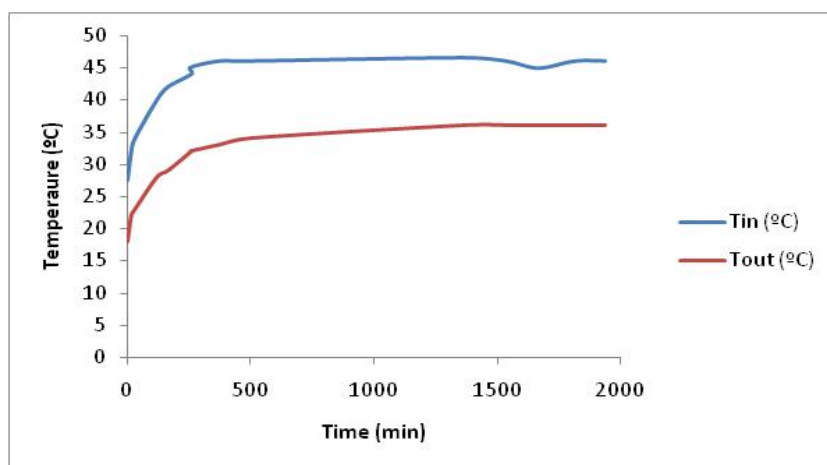

Figure 13: Evaluation Period of Coaxial BHE

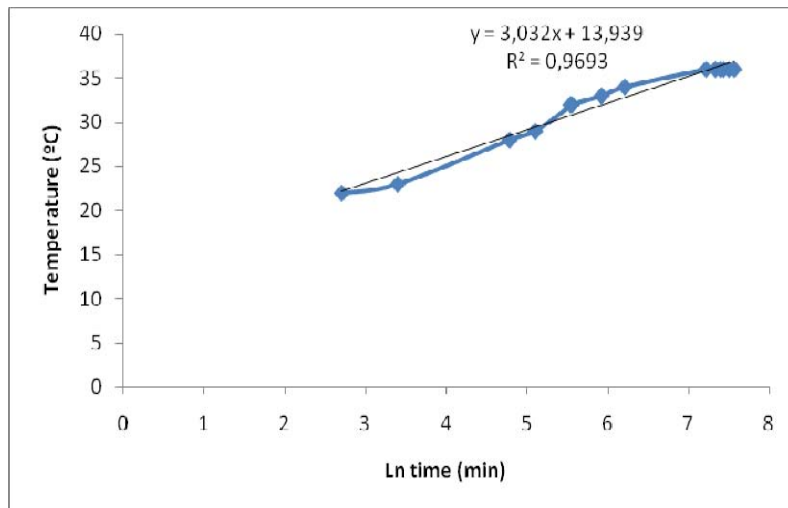

Figure 14: K determination for Coaxial BHE

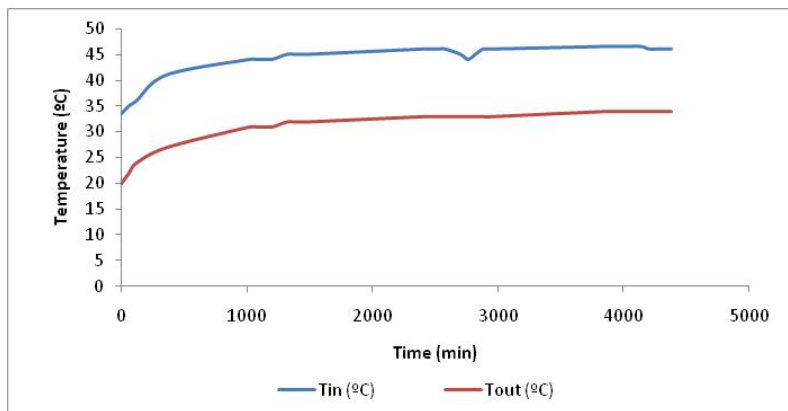

Figure 15: Evaluation Period of Double U BHE

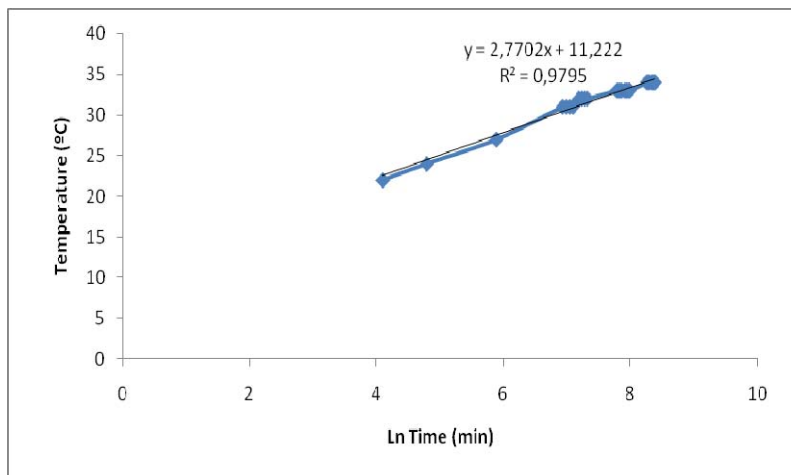

Figure 16: K determination for Double U BHE

The preliminary results are described in table 2.

Table 2 – Second test results for each BHE

BHE	K	Ground Thermal Conductivity (W/m°C)
Coaxial	3.03	2.62
Double U	2.77	2.87

In the second test, a heat rate of 8.0kW and a flow rate of 612L/h were established and similarly to the other test the evolution of the fluid temperature inside the borehole, against time elapsed was registered.

The duration of this thermal response test was 32 hours to the coaxial BHE and 73 hours to the double U BHE.

The test was also made in the heating mode and the evaluation of the thermal response test data was made by the same method as the previous one, using the formula (1).

As for the first test, inlet (Tin) and outlet (Tout) temperatures show the same evolution, with the accentuated growing in the first hours becoming almost constant.

Table 2 shows the k value (from the graphics) and the ground thermal conductivity calculated using equation 2.

From the table, it is possible to conclude that the double U BHE still shows a better result. The comparison between the results of both tests is not possible since the flow rate was different and for the first phase the heat rate was not maintained exactly constant. The second phase the thermal conductivity was slightly higher than on the first phase maybe due the difficulty to keep constant the heat rate. Nevertheless the ground thermal conductivity is very good, due to soil characteristics described in section 2.2 and due to the presence of ground water.

4.2 Integrated System Tests Results

Preliminary data analysis allows having some conclusions about the installation performance.

In the heating mode the inlet temperature of the secondary circuit was almost constant during the test period, reaching values between 44°C and 45°C.

The BHE outlet water temperature was between 15°C and 16°C, being around 10°C and 11°C the BHE inlet. Figure 17 show the results recorded in the two circuits.

These values are according to the expected ones during the design phase, showing good performance in the terminal units (fan-coils, secondary circuit) and in the boreholes (primary circuit).

With an average COP of 5.23, the GSHP had the same result in real conditions as in the lab tests, as shown in table 1. The maximum COP value obtained was 6.05, with a

heating capacity of 12.11kW, and an electric power of 2 kW. The outside temperature was about 15.5 °C.

5. CONCLUSIONS

In Setubal, climatic conditions demand both heating and cooling loads, being the cooling load a substantial require. As GSHP is a new application in Portugal, the site offers optimum conditions for testing the setting-up of a GSHP system for heating and cooling in Southern Europe.

Some preliminary tests were made on the primary circuit and in the installation as a whole.

To test the primary circuit, a thermal response test was performed. As mentioned in section 3.1, the thermal response test allows to achieve the efficiency of each BHE type and to determine the effective ground thermal conductivity.

In the first test, an experimental device was used and the test was set for the heating mode. The evaluation of the thermal response test data was made by using the line source theory, considering the formula (1).

Analyzing the results of temperature evolution in time, inlet (Tin) and outlet (Tout) temperatures showed the same evolution, with an accentuated growing in the first hour, becoming smoother and almost constant along time.

Considering the three BHE types, the measured parameters allowed the calculation of the BHE output and the ground thermal conductivity. From the results, it is possible to conclude that the double U BHE showed a slightly better result, allowing higher heat dissipation. However due to the difficulty to keep constant the heat rate from the heating source the analysis of the results from first test phase should be done only in qualitative way for different borehole configurations.

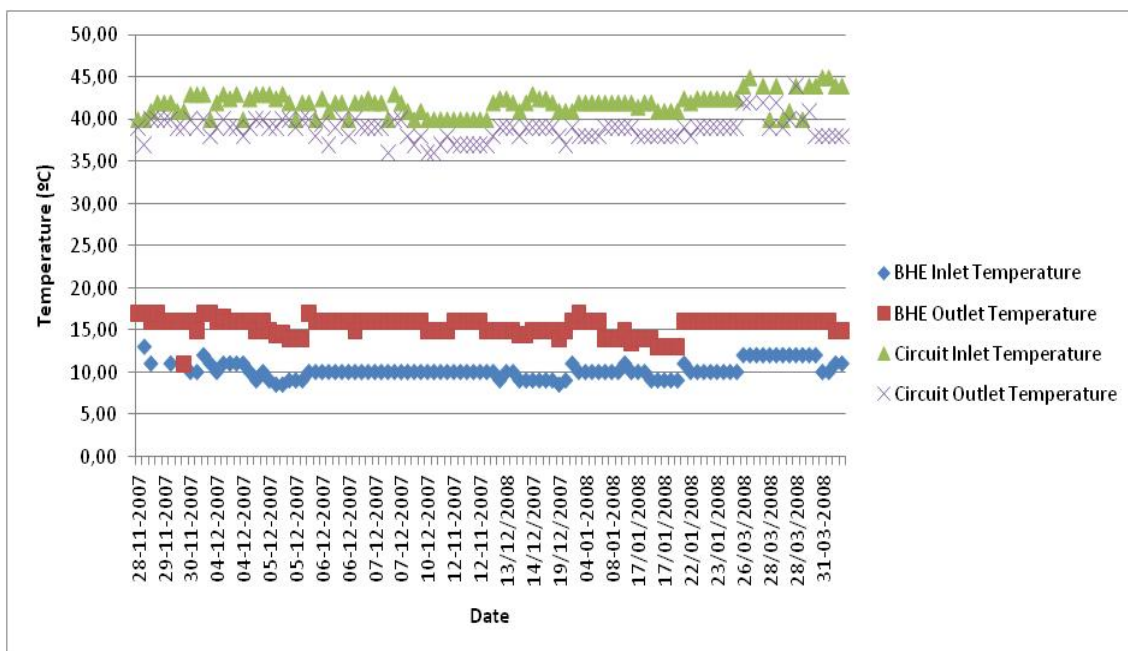

Figure 17: GSHP source and supply temperature

The second thermal response test results showed the same trend of results, but with a better thermal conductivity, in spite of the different flow rate. Double U BHE type reached a thermal conductivity of 2.87W/m°C. This high value is due to soil characteristics described in section 2.2 and due to the presence of ground water in large amount.

Considering the demo site installation the GSHP COP was, in average, 5.23. The results values were according to the expected ones during the design phase, showing a good performance in the terminal units (fan-coils, secondary circuit), boreholes (primary circuit) and GSHP, running in real conditions.

In spite of the good results, validation of this preliminary analysis must be done with an enough set of monitoring data in the heating and cooling mode. The authors expect to have more results to show in the final technical paper, both in the thermal response test as well as the in the integrated system tests, running in summer conditions.

ACKNOWLEDGEMENT

The authors wish to acknowledge the European Commission for the support in the Research, Technological Development and Demonstration activities and also all partners from the GROUNDHIT project. This project was supported by the European Commission within FP6 under No. TREN/04/FP6EN/S07.31402/503063; the responsibility for the content of this publication, however, is with the authors only.

REFERENCES

- Coelho, L., Garcia, J., Rosado, A.: First Report on Setúbal Demo Site Monitoring, Ground Coupled Heat Pumps of High Technology Project (2007).
- Eklöf, C. and Gehlin, S.: GROUNDHIT – TED - a mobile equipment for thermal response test, *Master Thesis 1996:198E*, Lulea University of technology, Sweden, (1996).
- Florides, G., and Kalogirou, S.: First in situ determination of the thermal performance of a U-pipe borehole heat exchanger, in Cyprus, *Applied Thermal Engineering* 28, 157–163, (2008).
- Gehlin, S.: Thermal response Test - method development and evaluation, *Doctoral Thesis*, Department of environmental Engineering, Lulea university of technology, Sweden, (2002).
- Mands, E. and Sanner, B.: In-situ-determination of underground thermal parameters, *International Summer School on Direct Application of Geothermal Energy*, (2001)
- Sanner, B., Karytsas, K., Abry, M., Coelho, L., Goldbrunner, J. and Mendrinós, D.: GROUNDHIT – advancement in ground source heat pumps through EU support, *Proceedings*, European Geothermal Congress 2007, Unterhaching, Germany, (2007).
- Zhao, J., Dai, C., Li, X., Zhu, Q. and Li L.: A Case Study of Ground Source Heat Pump System in China, *Proceedings*, World Geothermal Congress 2005, Antalya, Turkey, (2005).